



# Livingston Youth Baseball/Softball

## Coach Packet

2024



[www.cityoflivingston.org](http://www.cityoflivingston.org)

**Rec Office - 209-394-8830**

# Department Philosophy

## Think Safety First!

### Department Mission

The Mission of the Recreation Department is to provide recreational opportunities, athletic programs, special events and recreational, educational and cultural classes for the residents of the City of Livingston.

### Department Duties and Responsibilities

The Recreation Department is responsible for recreation programs, athletic programs, special events and recreational, educational and cultural classes that

1. Encourages community spirit and fellowship.
2. Allows all players a equal opportunity to participate.
3. Instructs players in the development of heir physical and mental capabilities.
4. Builds good character and encourages team work.
5. Develops good sportsmanship.
6. Implements the principles of fair play.
7. Improves physical fitness.
8. Have fun!

**It Takes A Village**

**2**

# Coach Responsibilities

- ⇒ Implement the Department Philosophy
- ⇒ Sign a coaches code of ethics
- ⇒ Recruit Assistant Coach & Team Mom (finger prints)
- ⇒ Hold a Parent Meeting—See Parent Meeting Sheet
- ⇒ Hold a minimum of 2 practices per week
- ⇒ Communicate with the team and their parents
- ⇒ Use your Player Progression Sheet as a guideline for instruction to your players.
- ⇒ \* will provide upon request
- ⇒ 8. Take Care of Equipment and turn it in in the same condition as you received it.

**See Player Progression Sheet**

# Coach & Parent Meeting Outline

## TO MY PARENTS:

**My goal is to have every child feel that they played a great game that day.**

**Objectives** - With this age group, I have 5 primary coaching objectives which I believe are equally important.

1. Help your child develop the skills necessary to be successful at this level and to prepare your child for next season.
2. To have fun and have the kids develop a love for the game.
3. Learn about the importance of teamwork and sportsmanship.
4. Give positive reinforcement based on effort rather than results.
5. Provide a safe and healthy environment for all the kids on the team.

## Playing Time and Positions

In this League there can be a drastic difference in skill level among the kids. I want to give the kids an opportunity to play a number of different positions and I'll make sure each player gets a chance each game to play in the infield for a couple of innings. I will not have a player pitch or catch that I don't feel has the ability to play the position at this time. This really is a safety issue as much as anything. I want to put kids in positions where I feel they have the best chance of being successful. That doesn't mean they won't have the ability by the end of the season and I will always work with the kids at those positions during practice if they are interested.

## Player Expectations

1. Have fun and always give your best effort.
2. I expect players to always show respect for the coaches, umpires, parents, and other players on the team.
3. Spend time outside of practice playing baseball.

## Parent Expectations

1. Please try to get your child to practice and games on time. I know this can be difficult at times and impossible at other times, but it's really hard to conduct practice or get ready for a game when players show up late. If you know your child will be late or won't be able to make it to a practice or game, please let me know in advance if possible.
2. Help out with team volunteer opportunities. We have a number of items that require parent help. Base Coaching, Team Mom etc...
3. Get involved in playing Baseball/Softball with your child. This may be helping out with at practice or playing catch in the yard on days we don't practice. Kids love it when their parents get involved. There simply isn't enough organized practice time for the kids. They need to work on the skills they learn at practice at home also.
4. Please encourage good sportsmanship by demonstrating positive support for all players, coaches, and officials at every game and practice. Please cheer for your child during games, but try to keep from yelling instructions to them. Remember this is their opportunity to enjoy playing in the game. Much of the fun is lost if their Mom or Dad is always yelling instructions.
5. Please let me know if you have a problem with me or something that is happening. Same holds true if your child isn't happy about something. I want to know if there is a problem right away. With this age group, very small things can cause a child to be upset. These problems can be fixed very easily if I know about them.
6. Safety is a primary concern for me. Unfortunately, I can't watch every child every second. If you see any situation that you believe is a safety concern, please step in and help. Make sure you follow up with me so I know what has happened.

I'm looking forward to a fun and rewarding season. If you have any questions or concerns, please don't hesitate to call me.

Coach \_\_\_\_\_ Phone

# **Practice Begins**

## March 18th

### **Recruit Parent Help**

3 contact Rule applies to Rookies and below.

#### **3 Contact Rule**

In order to create continuity in the entire league and to address parental concerns we have developed a 3 contact rule which is; You may only have 3 – 1.5 hour contacts per week for you and your team.

Examples:

3 practices per week

3 games per week

2 games and 1 practice

1 game 2 practice

Etc....

This is even too many for the younger kids. Minors and Major coaches please keep in mind that this is a recreation league not a competitive or travel league. Children do have lives other than baseball or softball.

# Tip for making Parents Happy!



Make a schedule for the parents to post! Last minute notifications sends parents into outer space. Give them a sheet with every practice on it so they can plan accordingly. Believe me it will help keep your parents happy!

If you do plan an extra practice give them a day or two notice.

## **practice schedule**

# **Equipment Check Out**

**Pick up equipment between  
10am - 2pm on Saturday 3/16  
at the sports complex snack bar.**

**2600 Walnut Ave.**

Please teach your players to respect our equipment. Replacing equipment is costly. Throwing helmets and hitting the bats on poles is unacceptable. Please put equipment back in the provided bags in an orderly manner. Over stuffing them will break the zippers.

**Due to lack of Space no equipment will  
be stored for you in the concession stand.**

**We Apologize for the inconvenience.**

**T's and pitching machines  
can still be checked out from the snack bar.**

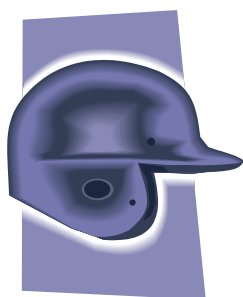

**7**



# Team Mom & Assistant Coach



Team Mom or Dad will be one of your most important assets. They will be able to help you with:

1. the snack schedule
2. Team banner
3. phone calls

They do not need to be printed unless they are in the dugout with the kids. I suggest you get them printed . It is free and it will give you a back up to assist with the kids.

**ALL Assistant Coaches must be cleared through the Recreation Office.**

Allowing parents to work in a coaching capacity that have not passed our background check puts you in a liable situation. Don't take the risk have them cleared.



# Team Banner

## 3 ft high X 5 ft wide

builddesign.com banners for about \$40

and it takes 10 days to get it back order right away and ask parents to pitch in a couple dollars!

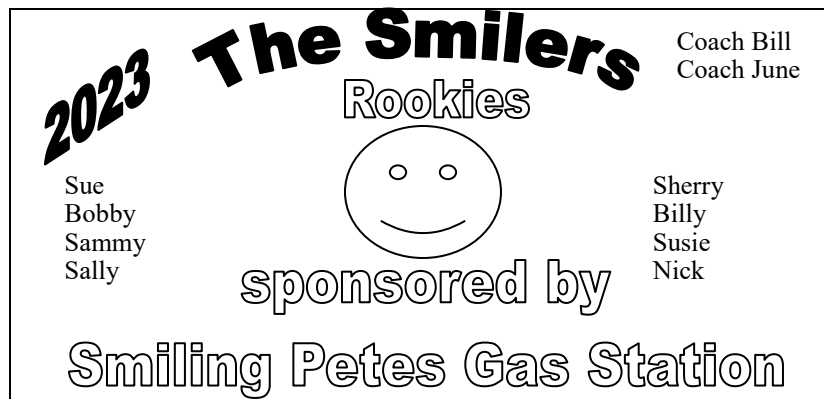

- #1 Tool we use to say thank you to our sponsors.
- #2 Tool to identify your team.
- #3 Banners look great in your team photo.

CONTENTS: Size - 3' X 5'

- #1 Team Name, Division, Names of players and coaches
- #2 Made of material that withstand wind rain etc...

Banners are to be displayed at every game. You never know when your sponsor may show up to watch your team play.

Banners will be used during Opening Ceremony.



# Opening Ceremony

April 12th - line up 5:45pm  
Memorial Park/Alvernaz Field

**COACHES WHAT TO DO FOR OPENING CEREMONIES!!!**

FIND YOUR TEAM NUMBER AND STAND BY IT

Gather team and line up by the gate at the end of the third base line on  
PARK STREET sidewalk.

Parade starts with the umpires carrying the American Flag, T-Ball,  
Rookies, Minor Boys and Major Boys then Softball Mini Tails, Minor  
Girls and Major Girls, then the Mite Giants .

**WE WILL MARCH IN AT 6PM SHARP**

Teams will march around the outfield fence to the First base line come  
up the first base line to first base and then follow the infield dirt line to  
your position according to the map. Mite giants line on the First base  
line. and the umpires will line up on the third base line.

**When your team is called please run up to the pitchers mound and  
wave to the fans or do a cheer. Go back to your spot and keep your  
kids quiet. Please encourage your kids to cheer on the other  
teams!!!**

It is over after the mayor throw out the first Pitch.

**Tell your KIDS your TEAM  
number and have them line  
up at the number on Park STREET**

**Guns & Hoses Game to follow OC  
10**

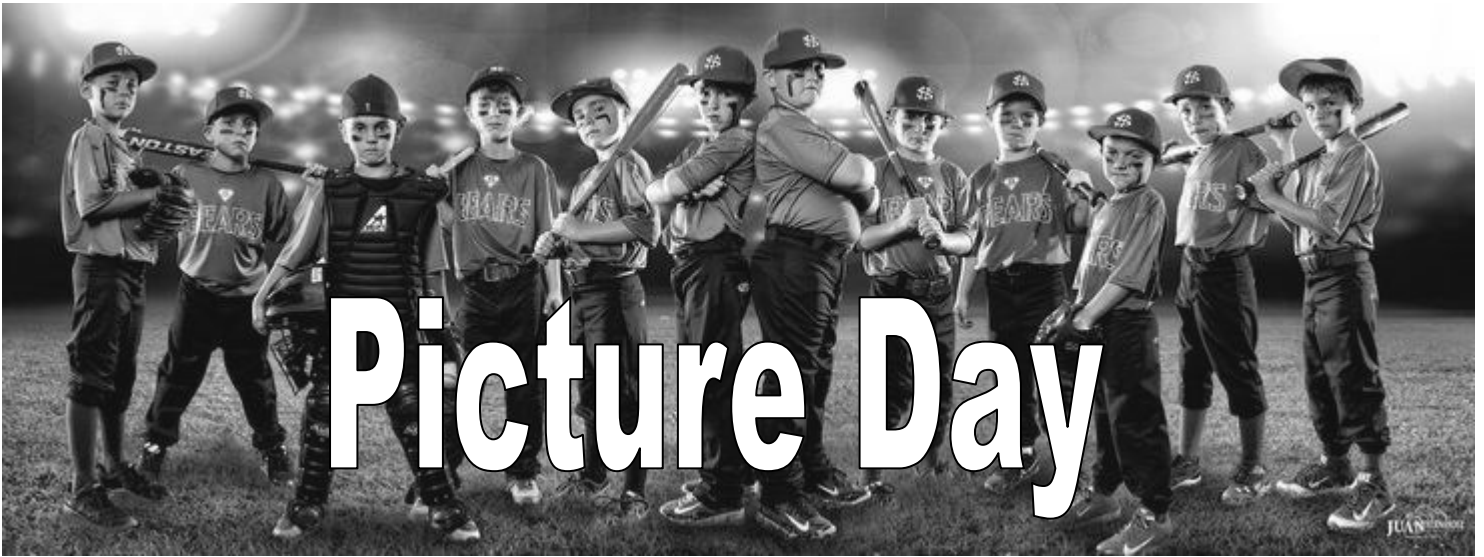

**Coaches MUST tell  
the Photographer they are a coach  
You get a free picture.**

We have a NEW photography company Youth Sports Pros.

Pictures are not included in the League Fee.  
Picture packets that must be completed at picture time with payment. Check or cash(exact change)

Pictures can also be ordered online at  
[www.youthsportspros.com](http://www.youthsportspros.com)

Please be sure all forms are complete.  
BE ON TIME. You will receive a schedule when you get your shirts.

**Picture problems are dealt with by the  
photographer directly at 1-888-402-0201**

**The week of April 22nd  
11**

# Raffle Tickets

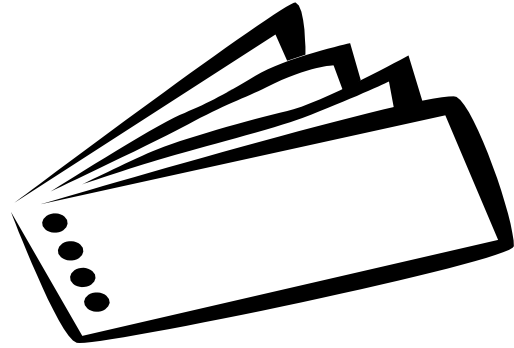

Every player was given a packet of 4 tickets at registration. Tickets are \$5 each and the purchaser has a chance to win \$1000. These ticket stubs are due to City Hall by Thursday, June 6th at 4:30pm.

Drawing will be held Friday, June 7th at 12pm at City Hall

Please Remind your players to turn in their raffle ticket stubs.

Winner will be contacted

# End of the Season

Due to lack of participation. The Rec. Department will no longer host a “Closing Ceremony”. We are encouraging each team to do their own celebration. All parks have been reserved for our leagues on June 9th, should you choose to use them.



Medals and pictures: The Recreation Dept. will contact you when they are ready for pick up.

Usually about a week before the season ends.  
**PLEASE RETURN PICTURES AND MEDALS THAT ARE NOT PICKED UP TO THE OFFICE WITH THE PLAYERS NAME ON THEM**



# Equipment Return

Please return your equipment on the last day of your games. If you are at Lil Guys turn it in there. If you are at the sports complex turn it in there. You will be **billed \$350** for equipment not returned.

Due to equipment wear and tear travel teams may no longer borrow city equipment.

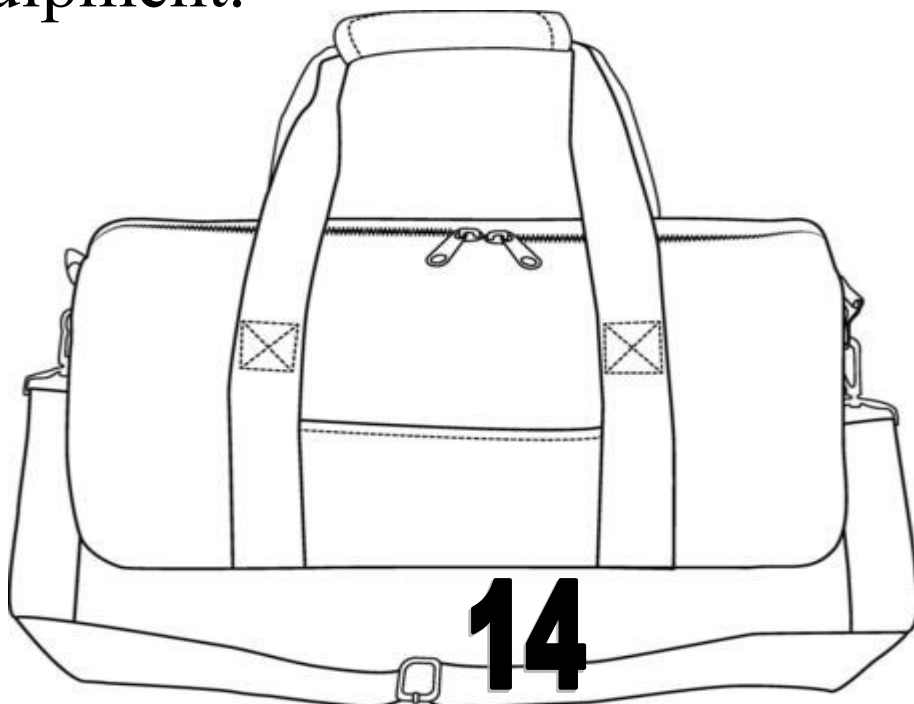

# *Team Special Meal Deal*



Hot Dog & Soda

**\$3 each**

# *Healthy Meal Deal*

**NEW OPTION**



Hot Dog - Water -  
fruitsnack

**Must be ordered and paid for prior to game.**

**Meals will be ready when the game is over.**

**Once ordered there is NO CANCELLATIONS.**

**15**

# How to Maintain Positive Character

- Remind yourself the league objectives.
- Fundamentals and good sportsmanship.
- Let go of the aggressive competitive spirit.
- Encourage players to do their best.
- Remember the NO TOLERANCE POLICY
- for poor sportsmanship.
- Every person gets the same trophy at the end of the season.
- Build and develop a love for this great sport in our kids our you can cause them to hate the sport and never want to play again.

PLEASE YOUR CHARACTER DOES COUNT!!

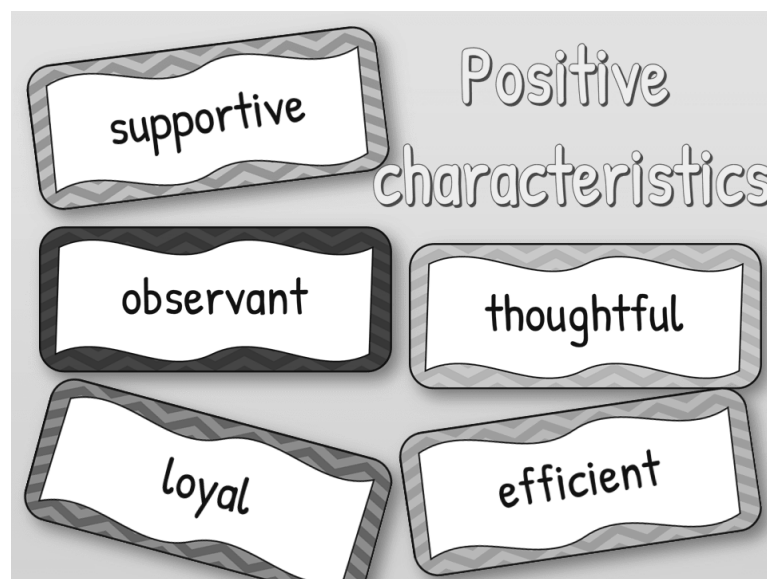



# Incident Reports

If you have a problem with a parent, player, coach, fan or staff member, please take the time to document the issue. I do not receive complaints unless they are in writing. Complaints in writing can and will be addressed. Incident Reports are available at the Snack Bars. All incident reports against any individual is placed in their file. If any of the above are breaking rules or code of ethics the Recreation department needs to know about it.

## Player/Parent Code of conduct

You will be given the parent player code of conduct for you players and your parents to sign. Keep these with you at all times. It helps for you to be able to remind parents what they agreed to when they attend games etc....

## Parent Meeting with Department

This is not for every player only those new to the league. We use this meeting for all sports so if they attended one for basketball they do not need to attend for baseball/softball.

Players needing meeting are highlighted on your roster. Players needing meeting may not play until parents attend.

**DATE OF PARENT MEETING: April 3rd at 6pm  
Sports Complex - Patio area**

**Please REMIND your parents  
if the umpire ejects  
them from a game the  
child has to go too. =(  
Umpires are Kids  
speech!**





# SAVE the DATE



**2024**

*Livingston*

a family affair open to all ages

# Splash of Color Run

**May 18th**

9am check in - Race Begins 10am

Starts and Finishes at  
Memorial Park

1339 Park St. Livingston, CA

**5K Run/Walk**

**\$30 Adult VIP Package**

**\$25 Youth VIP Package**

VIP PACKAGE INCLUDES: T-SHIRT, 5  
COLOR STOPS, COLOR POD FOR CHECK  
IN PARTY COLOR BLAST SUNGLASSES

(Color Kits are only available through pre-registration)

**Run ONLY - No Frills**

**\$20 advance**

**\$30 at event**

**Sponsorships**

**Available**

pre-registration required - deadline April **15** 2024

sun glasses, face mask or bandana recommended

for more info 394-8830

**No Games on May 18th!**

**19**

# Upcoming 2024 Recreation Activities

Guns and Hoses / Police VS Fire Softball Game  
Friday April 12th after Opening Ceremonies Alvernaz  
Field

May 18th Splash of Color Run Starts at Memorial  
Park—Registration Deadline is April 15th

Swim Team Registration - ongoing

Soccer Registration 5/23, 6/22, 7/13

Swim Lesson Registration May 22 & 29

Livingston Junior Giant Registration **online only begins  
April 1st**

Movie in the Park Date to be announced Presented by  
LUSD Teachers Union

Coaches Always Needed for all Youth  
Sports Programs

Call Recreation if you can help.



# THANK YOU

Thank you in advance for all the work and time you invest in our children. There are no words to express this. You are appreciated and it can never be said enough.



THANK  
YOU  
COACH